

KNC-500C3

CBN Saw Grinding Machine Series

3 Axes CNC Control

- Cutting Angle Hands-Free-Adjust Function
- Digital Parameter Input
- Self-Detection & Modular Control System

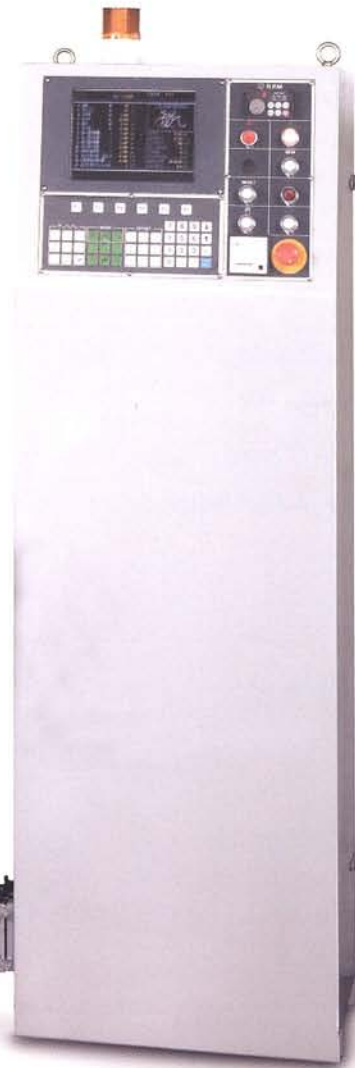
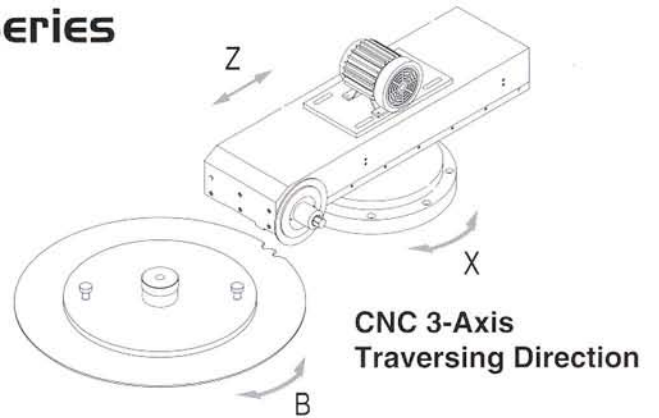

Tooth Form Grinding Function



KNC-500C3

CBN Saw Grinding Machine Series

Specifications

Capacity	KNC-500C3
Saw blade diameter	ø70mm ~ ø500mm
Pitch range	24 mm (max.)
Grinding teeth limit	10 ~ 998 teeth
Thickness of saw blade	6mm (max.)
Range of cutting angle	0.01° ~ 30°
Feeding speed	2 ~ 60 teeth/min
Total electric power	9kw
Grinding Wheel	
Diameter	ø200mm
Inner diameter	ø32mm
Motors	
Wheel motor	3.75kw / IP65 protection class
Z-axis driving motor	1kw / AC servo motor
B-axis driving motor	1kw / AC servo motor
X-axis motor	0.5kw / AC servo motor
Coolant pump motor	1.5kw / IP55 protection class
Coolant	
Capacity	60liters/min
Pressure	9kg/cm ²
Coolant tank volume	250liters
Machine Dimension & Weight	
Net weight	1600kgs
Gross weight of packing	1950kgs
Packing size (W x H x D)	2140 x 1930 x 1730 mm

• The above specifications subject to change without prior notice.

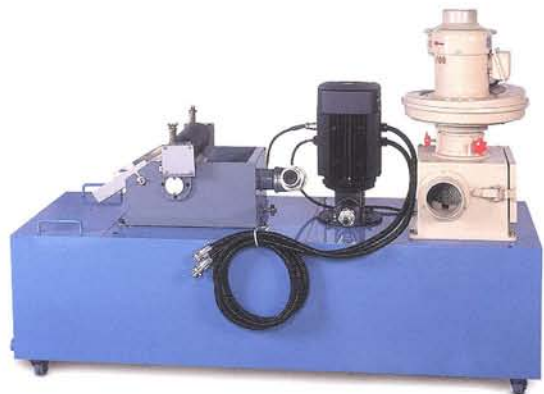

HIGH PRESSURE COOLANT DEVICE

- The coolant device employs a high pressure pump, which provides a powerful flushing to wheel for preventing chips from adhering on the wheel surface.
- Equipped with an oil mist collection device.
- Equipped with a magnetic separator for reducing deterioration and pollution on the coolant.

Layout Drawing

Unit: mm

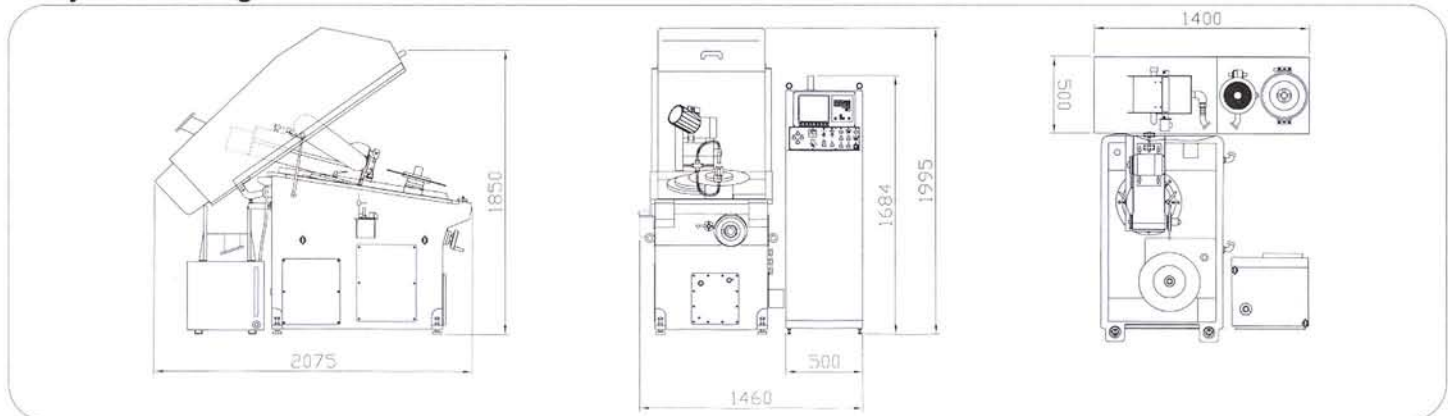

Kentai®

KENTAI MACHINERY CO., LTD.

No. 175, Datong 1st St., Wurih, 41449 Taichung, Taiwan

Tel : 886-4-2338 8968 Fax : 886-4-2338 8768

e-mail : info@kentai.com.tw

http : // www.kentai.com.tw

AGENT